

Dr. Chaturi Singh
Senior Research Engineer
National Wind Tunnel Facility
Indian Institute of Technology Kanpur
KANPUR – 208016, INDIA



Email: chaturi@iitk.ac.in

Tel : 91-512-2596314, 2597159

Enquiry No. NWTF/IITK/2015/04

Date: July 08, 2015

Closing Date: July 24, 2015

Sealed Quotations are invited for the supply of the following reputed brand (like Pyrotech/Harmony/Godrej/Wipro) make customized Control Room Furniture from the manufacturers/authorized dealers/suppliers:

S. No.	Customized Control Room Furniture	Quantity	
1.	Control Desk	02 Nos.	
	Specifications		Details
	Control Desk Type and Specifications		Curvilinear shape (For complete details/specs, please refer Page No. 3-5 of this document).
	Approximate Dimension		4200(W)x1306(D)x775(H) in mm (Within $\pm 1\%$)
	Control Desk Material/ Components		Please refer section 1(b) on Page No. 5 of this document for Control Desk Specification and Material/ Components to be used.
	Electrical Accessories		The control desk should be supplied with all the electrical accessories installed
	Additional Requirement in LHS & RHS CPU Sliding Tray and Accessories Box		600(W)X450(D) size, 18mm thickness MDF Board Sliding trays (one each) are required to be installed in the box above the CPU.
2.	MEETING TABLE	02 Nos.	
	Specifications		Details
	Table Type and Specifications		Modified Oval Shape (For complete details/specs, please refer Page No. 6 of this document).
	Approximate Size		2400(L)x900(W)x750(H) in mm (Within $\pm 1\%$)
Material/ Components	Please refer section 2(b) of this document on Page No. 6 for Table Specification and Material/Components to be used.		

Terms and Conditions for Supply of the Items listed in the above Table:

1. All sealed quotations should reach the undersigned by **July 24, 2015**.
2. Validity of the Quotations should be at least for **60 days**.
3. Delivery Period within **06 weeks** from date of Purchase Order.
4. All the items mentioned in the above table are required to be quoted/supplied from the same make.
5. For the supply of the items, the venders/suppliers are required to provide dealership/ authorization certificate for the supply of the items.
6. The manufacturers/venders/suppliers are requested to provide complete drawing along with material/components specification for the quoted items.
7. Please quote giving unit price for the items. Quantity of the item to be purchased may increase or decrease.
8. The prices offered should be for free delivery at IIT Kanpur and should include installation charges (if any).
9. Please mention tax rates clearly, if applicable.
10. The supplied item should have at least **One Year Warranty**.
11. Payment Terms: As per the Institute Rules.



Address for the Quotation

Dr. Chaturi Singh
Senior Research Engineer
National Wind Tunnel Facility
Indian Institute of Technology Kanpur

1. Control Desk for Control Room

1(a) Drawing

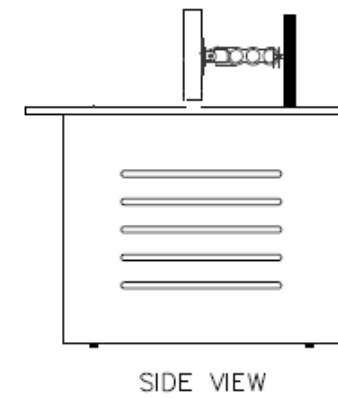
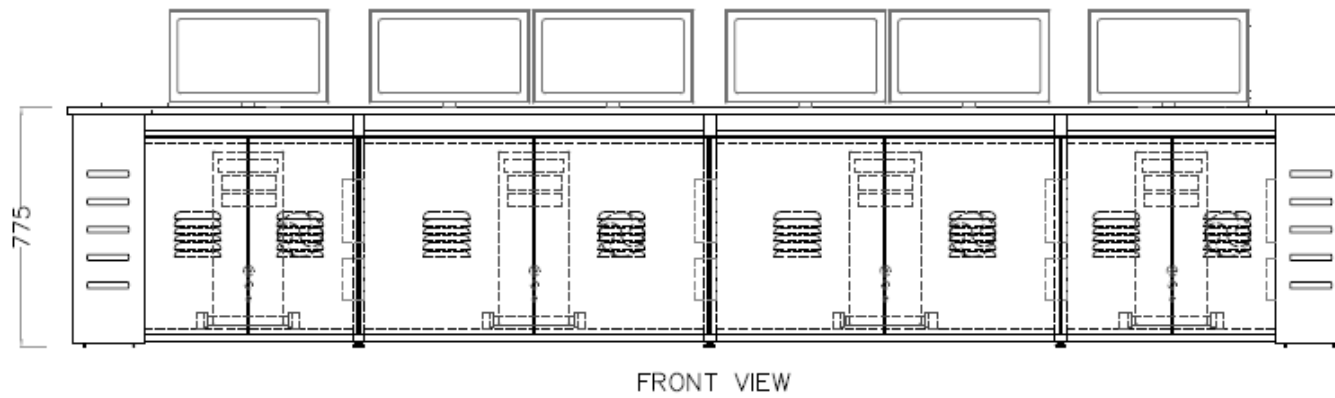
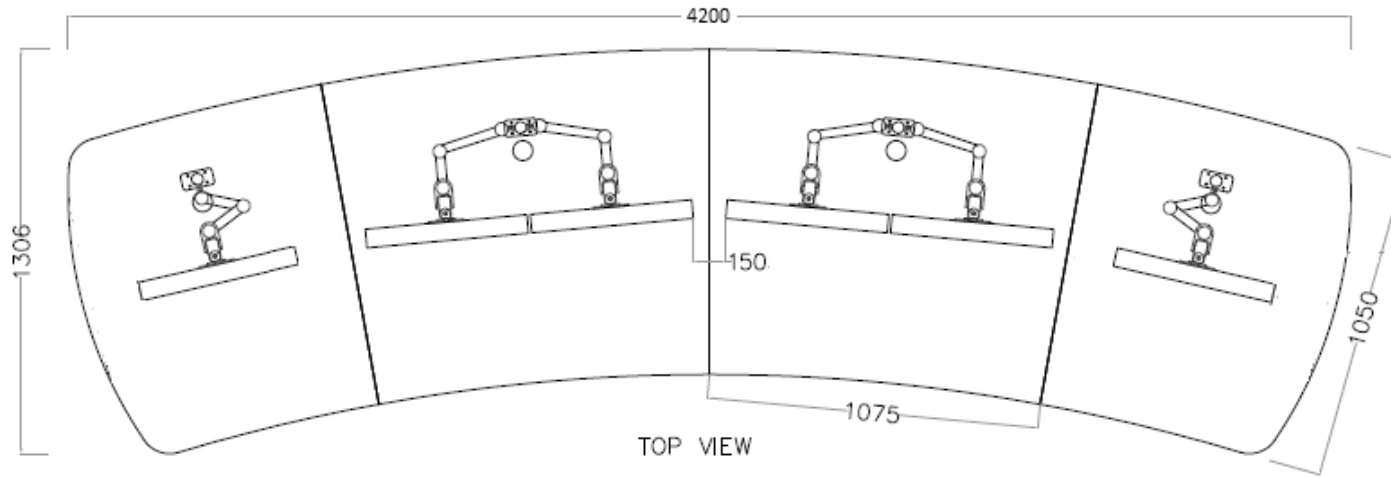

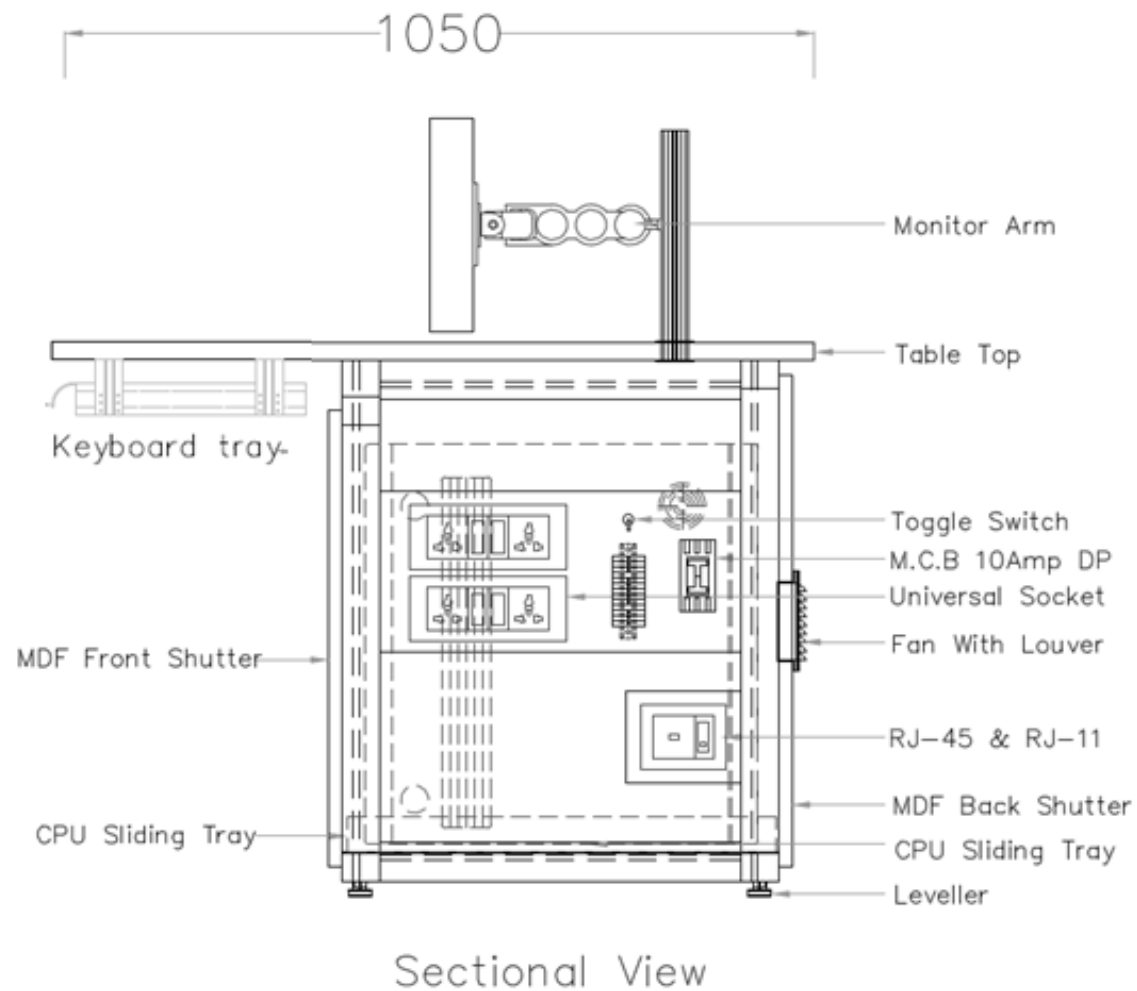

All dimensions shown in the above drawing are in mm.

1(b) Control Desk Specification and Material/ Components to be used:

1. Approximate Dimensions of Control Desk: 4200(W)x1306(D)x775(H)
2. 600(W)x450(D) size, 18mm thickness MDF Board Sliding trays (one each) are required to be installed in the LHS & RHS CPU Sliding Tray and Accessories Box above the CPU.
3. The control desk should be supplied with all the electrical accessories installed as shown in the above drawing.
4. The material/accessories to be used for the control desk are shown in the following table.

S. No.	Material Description			
1.	Table Top is Made of 25mm thick MDF Board. Colour : As Per Approval			
2.	Front and Bank shutter will be Made of 18mm thick MDF Board with 2mm thick Edge Bending all sides. Colour : As per Approval			
3.	Structure is made of powder coated heavy duty Aluminium extrusions. Colour: As per Approval			
4.	CPU Sliding tray & Electrical Accessories Box is made of powder coated CRCA sheet. Colour: As per Approval			
5.	CPU Size Considered as :- 560(H)x230(W)x550(D)			
6.	Keyboard tray has to be provided as shown in the attached drawing document			
Electrical Accessories				
S. No.	Description	Make	Quantity of Console	Total Quantity
1.	10 Amp DP MCB	Siemens	01 No.	04 Nos.
2.	13/10/6 Amp. Universal Socket	Anchor Roma	04 Nos.	16 Nos.
3.	RJ 45 Jacks	Anchor Roma	01 No.	04 Nos.
4.	RJ 11 Jacks	Anchor Roma	01 No.	04 Nos.
5.	Fan	Reputed	01 No.	04 Nos.
6.	Toggle switch for Fan	Reputed	01 No.	04 Nos.

2. Meeting Table for Control Room

2(a) Drawing

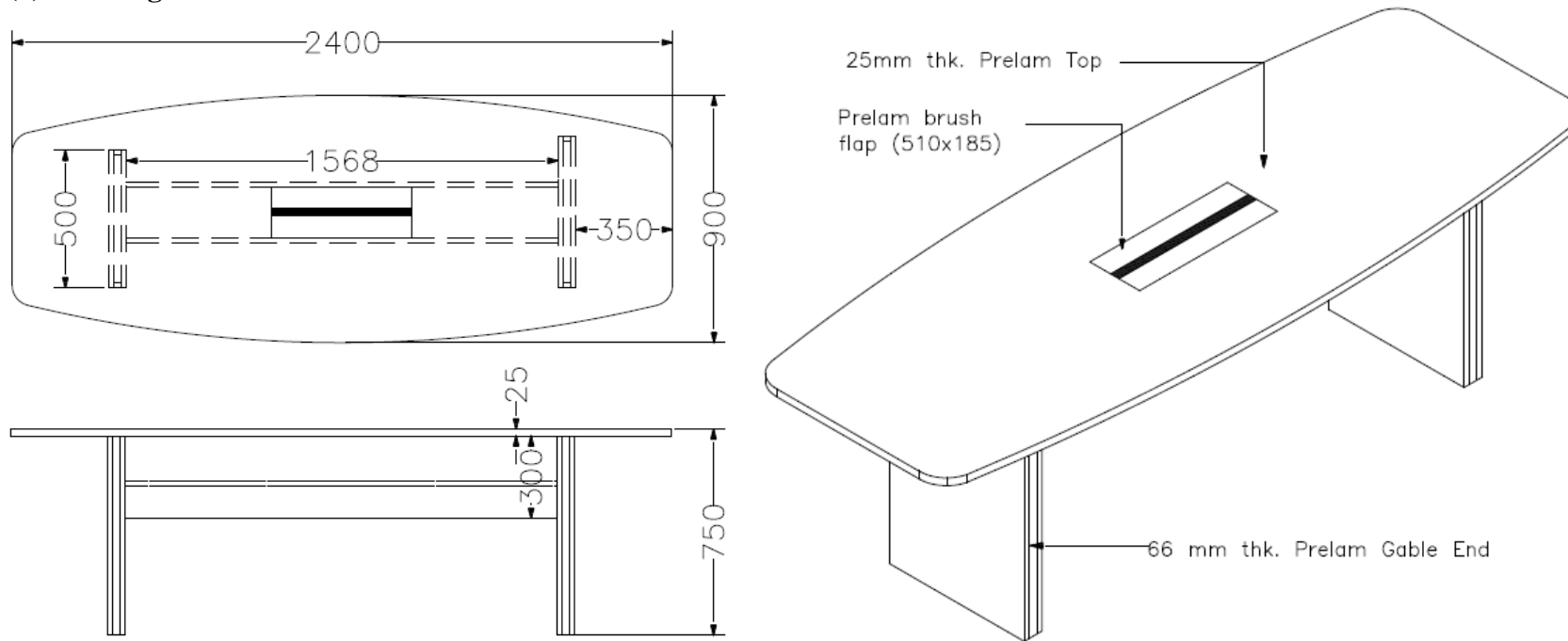

2(b) Table Specification and Material/components to be used:

1. All dimensions shown in the above drawing are in mm.
 2. Approximate Table Size:2400(L)x900(W)x750(H).
 3. 25 mm thick Prelam Table Top with 2mm thick PVC Edge Binding.
 4. 66mm thick Prelam Gable Ends with 500 width.
 5. Two nos. of modesties having size: 1568(L)x300(H) and made of 18mm thick Prelam Board
- Prelam brush flap (size: 510x185) shall be provided on the center of the table.