



Indian Institute of Technology Kanpur, Kanpur
Department of Mechanical Engineering

Inquiry no: ME/SDE/2017/DFBG/1

Date of Opening: August 11, 2017

Date and time of Closing: 5 pm, Aug 25, 2017

Sealed quotations are invited from the reputed manufacturers/ fabricators/ suppliers for the fabricated **cold flow model of a dual fluidized bed gasifier**.

Description of the Setup

The gasifier consists of two fluidized beds interconnected and sand is circulated with the help of air throughout the setup. Main components are a gasifier, riser, gas solid separator called diffuser, standpipe, downcomer and a loop seal. Pressure tapping holes are given at different locations in the setup to measure the corresponding pressure drops. A cut opening (sealable) in the lower portion of stand pipe is given to collect the sand samples. The setup will be made of a transparent material (acrylic/Plexiglas) as per the drawings and specifications provided in the accompanying document. This setup should be accompanied with a supporting stand (metal) to hold it firmly and a ladder for the operator, as required.

Specifications

Overall height of setup is 3.1 meter. Material of construction is transparent Plexiglas/acrylic except plenum chamber and distributor plates. Minimum thickness for material of construction (transparent) is 6 mm. Drawings are attached; additional information is given in the following table.

Component	Specification
Riser	circular cross section, height 2.5 meter, D: 65 mm
Gasifier	Annular cross section, height: 1.7 m, External Dia.: 350 mm, Internal Dia.: 65 mm
Diffuser	It has two sections. Lower one which is connected to riser is a diverging nozzle and upper one is of cylindrical cross section. It has one baffle plate (hollow conical type) fitted to the top wall of diffuser to obstruct the sand carryover coming out of riser. This part should be detachable from remaining setup.
Downcomer	its purpose is to carry falling sand particles from diffuser to gasifier. It has cross section of quarter circle having Outer Dia. 145 mm and height of 1630 mm.
Distributor plate (tray) for gasifier	Bubble cap type. Air enters in to the gasifier through the distributor plate. It is made of a perforated plate with 17 holes to fit 17 bubble caps each with diameter 22 mm. Material :- SS
Plenum chambers of Gasifier	air enters tangentially to plenum chamber and enters in to gasifier through the distributor plate. Material is mild steel.
Distributor plate (tray) for riser	Bubble cap type. It is a perforated plate (thickness 6 mm) having three holes to fit three bubble caps each with diameter of 15 mm. (Material for both plate and bubble cap is to be stainless steel)
Loopseal	It is a box type chamber and is divided in to two sections of cross section (50×50) mm. gas enters from below of loopseal through two distributor



Indian Institute of Technology Kanpur, Kanpur
Department of Mechanical Engineering

	plates.
Distributor plates for loopseal	Two orifice type distributor plates for each section of loopseal. Each plate is made of a stainless steel mesh (sized 40 microns) sandwiched between two perforated sheet metals (thickness 6 mm, each) having 105 holes, each having diameter of 2 mm.
Pressure tap holes	There are total 14 pressure tap holes each of diameter 6 mm. Provisions must be provided to close these holes if not in use.
Standpipe	This is a vertical tube (square cross section) connecting to loopseal. It has a cut opening in the lower portion (circular cross section, 20×20 mm) from where sand samples can be collected. Suitable provision must be provided to close it if not in use.
Stand	A supporting stand/frame (material, Mild Steel) to hold the setup and a ladder for the operator.

All distributor plates should be attached with the help of flanges so that different designs of distributor plates can be fitted. Standpipe and loopseal should be attached with plenum chamber and riser respectively such that these can be detached.

Kindly also note the followings terms and conditions:

1. All quotations must reach the undersigned on or before the closing date.
2. Supplier/Vendor should submit technical and financial bid together in separately sealed envelopes.
3. Only manufacturer/ fabricator/ supplier may quote.
4. For further queries or discussion, please contact Mr. Saurabh Gupta (9903082909, email: saugupta@iitk.ac.in, sgamubesu@gmail.com).
5. Evaluation will be done on the basis of technical specification format provided as per our tender notice. Technical details for various components should be attached along with the quote.
6. Financial bid will be open only for those, who meet T&C and tender technical specification.
7. The format for specification is same as provided in tender sheet for supplier/vendors for submitting technical specification in their own letter heads.
8. Please do mention tender number clearly on envelope.
9. Please send complete contact details of the person/ organization to whom your company had supplied similar systems.
10. The supplier must have supplied systems to institutions of national and/or international repute.
11. Normal payment terms for the institute will be applicable (90% on delivery of the items and remaining 10% after satisfactory installation/inspection).
12. Warranty/Guarantee should be clearly mentioned. The warranty must start from the date of installation at IITK.
13. Validity of quotation should be at least for 60 days.
14. Maximum educational discounts should be applied.
15. The delivery period should be specifically stated. Earlier delivery may be preferred.



Indian Institute of Technology Kanpur, Kanpur
Department of Mechanical Engineering

16. The intender reserves the right to withhold placement of final order. The right to reject all or any of the quotations and to split up the requirements or relax any or all of the above conditions without assigning any reason is reserved.
17. The price should be FOR IIT Kanpur and it should also be inclusive of packing and forwarding charges, commissioning and installation charges at IIT Kanpur.

After sales service:

1. The vendor should have quick service support for IIT Kanpur with adequate service persons, spares & all required accessories.
2. Single point of contact for support: Vendor has to provide details of single point of contact viz. designation, address, email address, and telephone/mobile no.

For further queries, please contact Mr. Saurabh Gupta (9903082909, email: saugupta@iitk.ac.in, sgamubesu@gmail.com).

Kindly send the quotation in sealed envelope latest by Aug 25, 2017, 5 P.M. to the following address.

Address for the quotation:

Dr. Santanu De
Assistant professor,
Dept. of Mechanical Engineering
Indian Institute of Technology Kanpur,
Kanpur-208016 (U.P.) India.

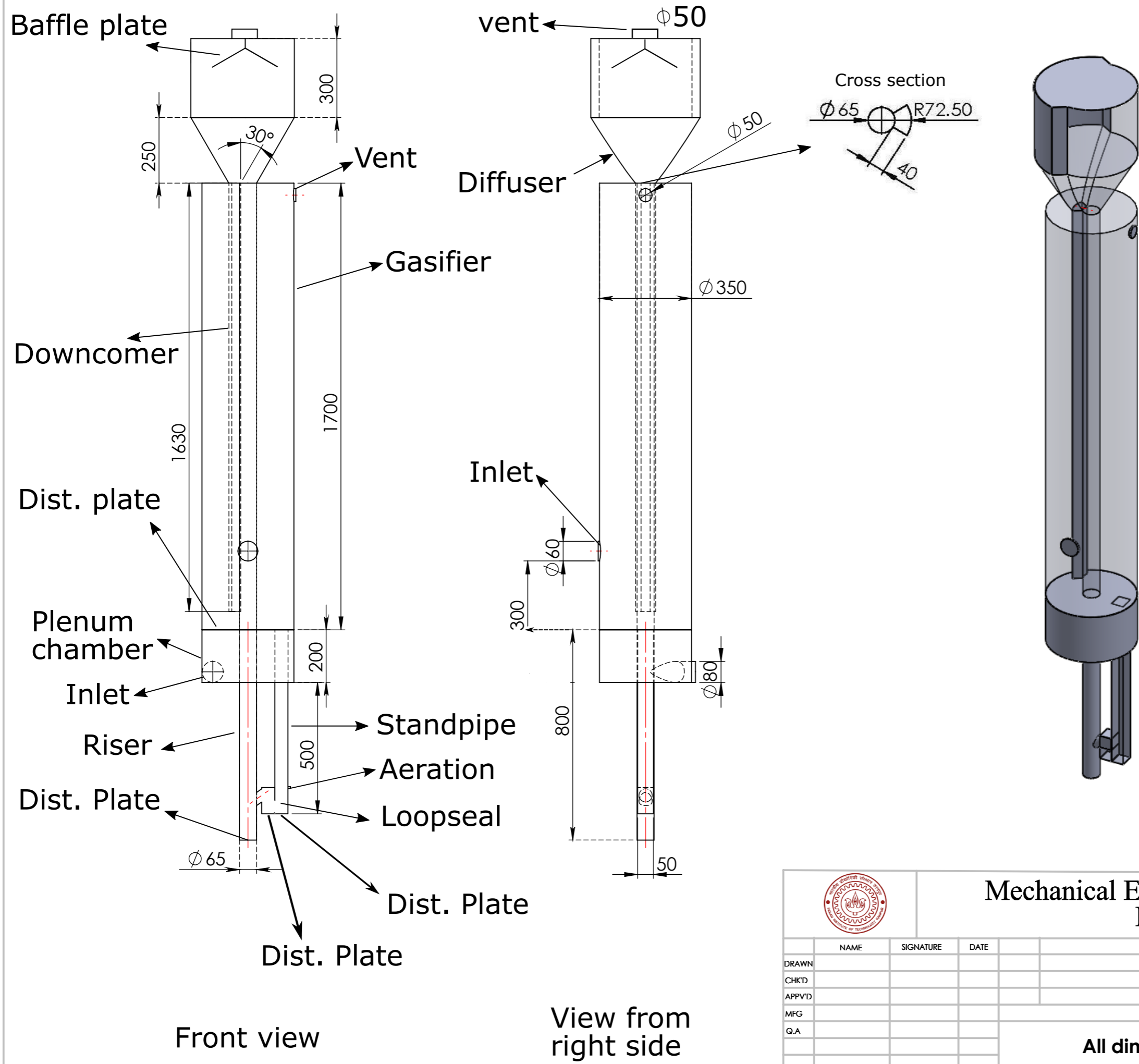

		Mechanical Engineering department, IIT Kanpur			
		NAME	SIGNATURE	DATE	TITLE:
DRAWN				DFB GASIFIER	
CHK'D					
APPVD					
MFG					
Q.A					
All dimensions in mm					
				SHEET 1 OF 1	

Enhanced view of Loopseal

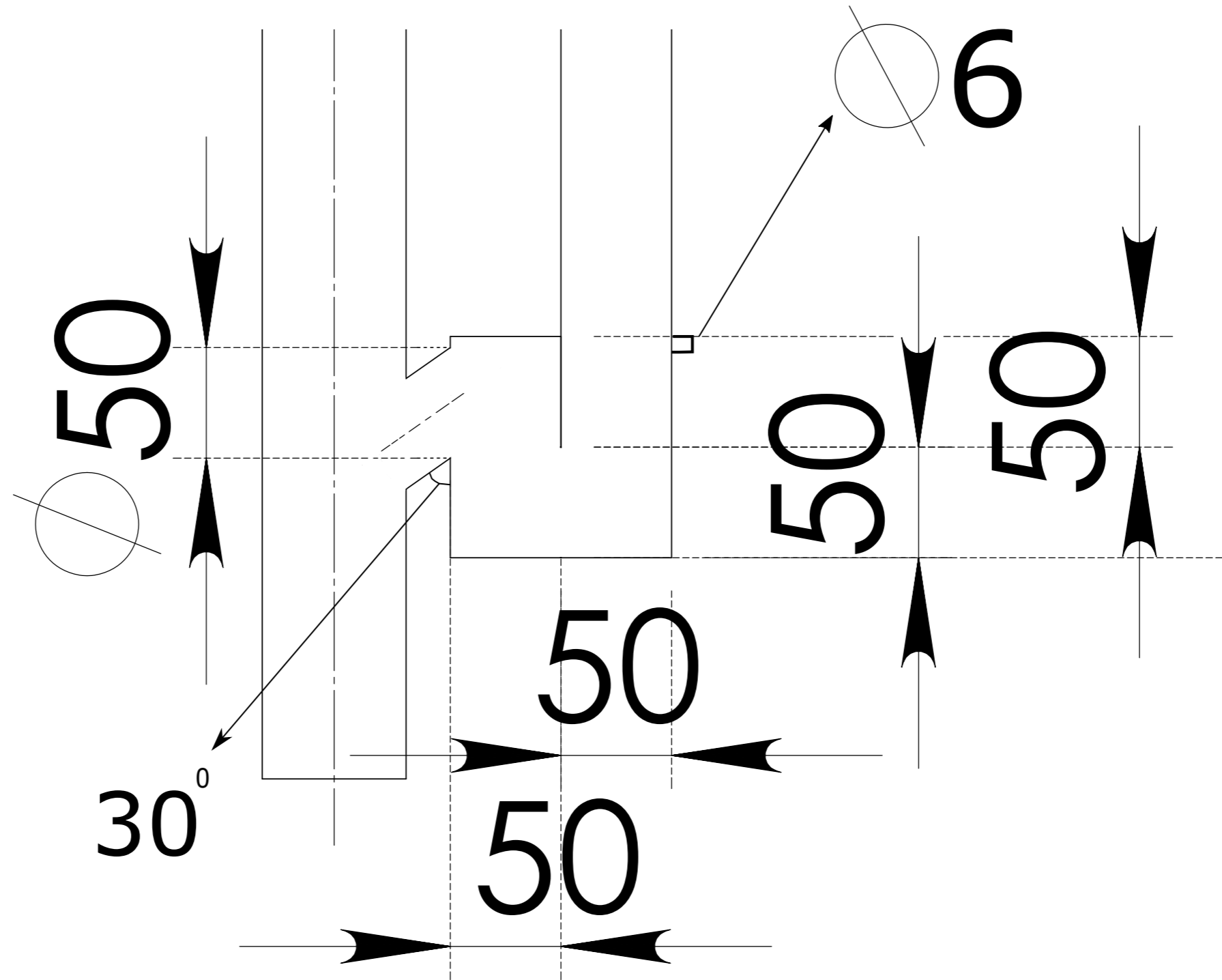

Mechanical engg. Dept.

IIT Kanpur

All Dim. in mm

